

ENDURO V 400

Endfinishing machine for facemilling and chamfering
of both ends of rods

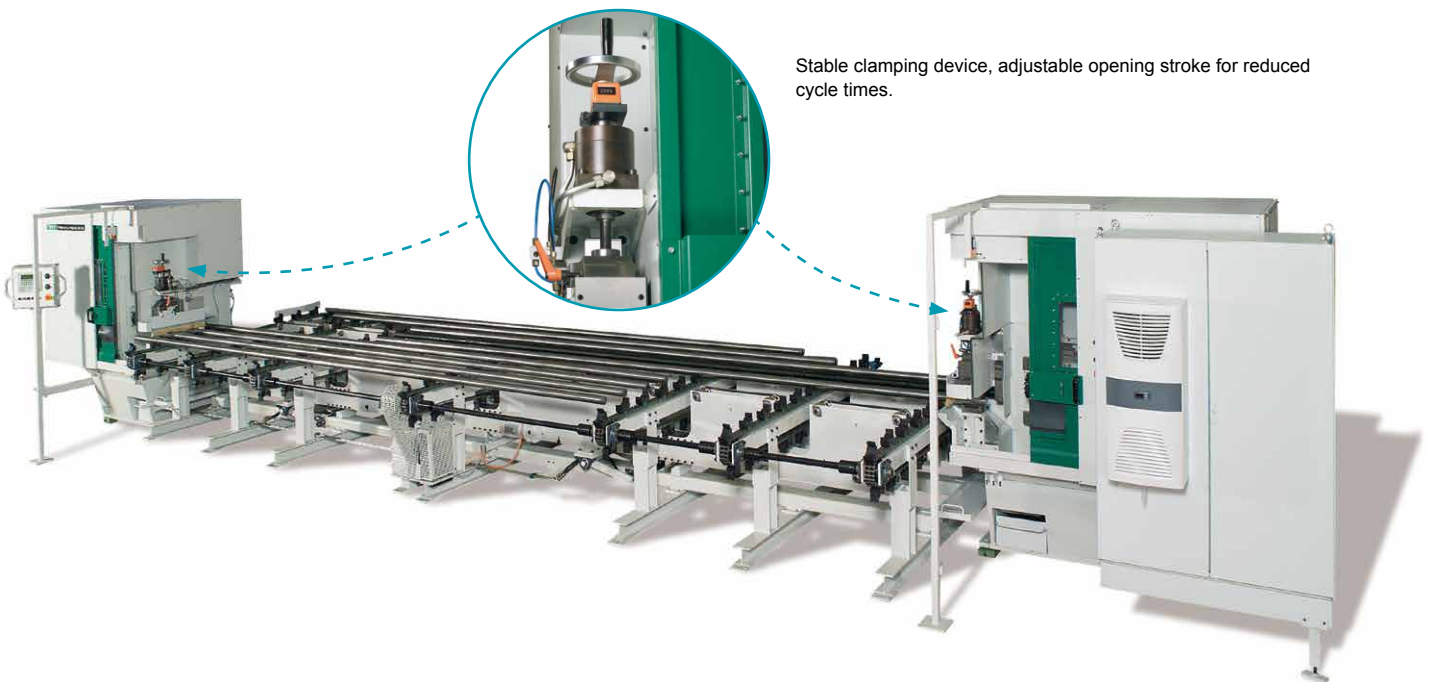

Stable clamping device, adjustable opening stroke for reduced cycle times.



With our Enduro V 400 you save precious time!

Processing operations, such as milling, drilling, centring and thread cutting are carried out on both ends, in one work cycle, and without manual intervention. Custom requests are possible at any time.

Technical details:

Workpiece diameter ranges	15 – 8 mm
	20 – 120 mm
Workpiece length ranges	2 000 – 6 000 mm
	2 000 – 8 000 mm
	2 000 – 12 000 mm

Possible operations:

- Squaring
- Turning round ends
- OD-turning
- Thread rolls
- Bevelling
- Centring
- Thread cutting
- Face milling

ENDURO V 400

Details:



For squaring and bevelling:
Longitudinal slide unit with a combination tool head



For use with thread cutting or rolling heads:
Longitudinal slide unit



For face milling and chamfering:
Cross slide unit



Step chain belt with a longitudinal roller conveyor and left-aligned workpiece limit stop for processing the first side, and a right-aligned workpiece limit stop for processing the second side

Required space:

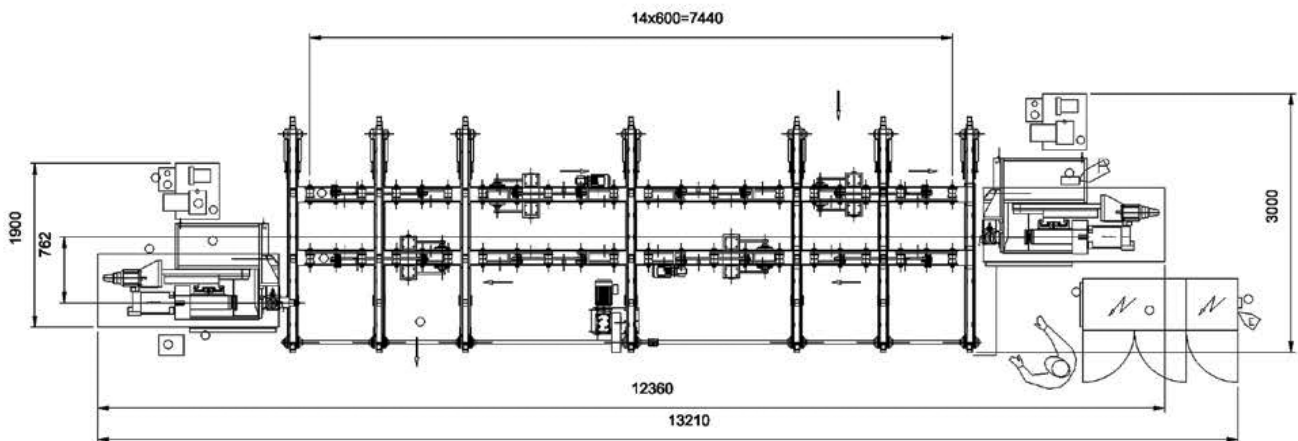

HIRSCHEIDER GmbH
Ferdinand-Porsche-Str. 5
73479 Ellwangen
GERMANY

info@hirscheider.com
Phone +49 7961 56499-0
Fax +49 7961 56499-340
www.hirscheider.com